

H-2000, T-2000

Head- and tailstock positioner with horizontal rotation.

One station positioner for workpieces requiring rotation about one axis. The free standing headstock can be mounted directly on the floor at an appropriate distance from the tailstock.

The tailstock T-2000 is ideal for uncomplicated welding fixtures where the welding current via the headstock is sufficient. Model T-2000C is equipped with a conductor and can be used in applications where additional welding capacity is needed.

The head- and tailstocks are equipped with MotoMount fixture mounting system and must be used together.

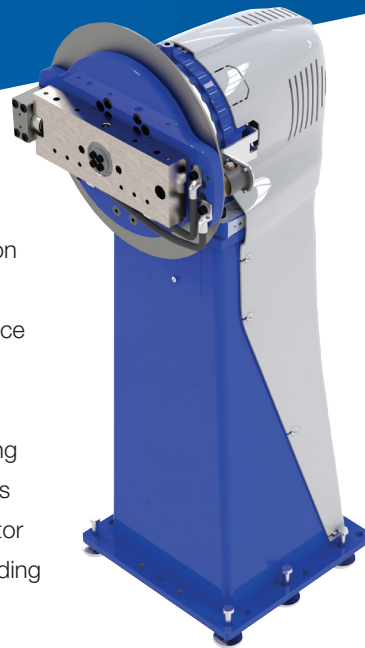

H-2000D



T-2000C
with conductor



T-2000

Technical data		H-2000D		
Max. capacity	load	2000 kg		
	offset	144 mm		
Motor power		3.7 kW		
Gear ratio	reducer	177:1		
Speed	nominal	8.5 rpm		
	maximum	23.5 rpm		
Torque	rated	3535 Nm		
	continuous rated	2828 Nm		
	peak	7070 Nm		
Rated welding current Standard	100%	2x 350 A		
	60%	2x 460 A		
Max fixture width		2000 mm	2500 mm	3000 mm
Headstock	Part No.	149528-100	149528-101	149528-102
Tailstock T-2000	Part No.	149512-100	149512-101	149512-102
Tailstock T-2000C	Part No.	149515-100	149515-101	149515-102

Fixture holder
MotoMount

Controlled by
YRC1000

Controlled by
DX200

Type	Part No.	D	A	H
H-2000	149528-100	2000 mm	1260 mm	1000 mm
	149528-101	2500 mm	1510 mm	1250 mm
	149528-102	3000 mm	1760 mm	1500 mm

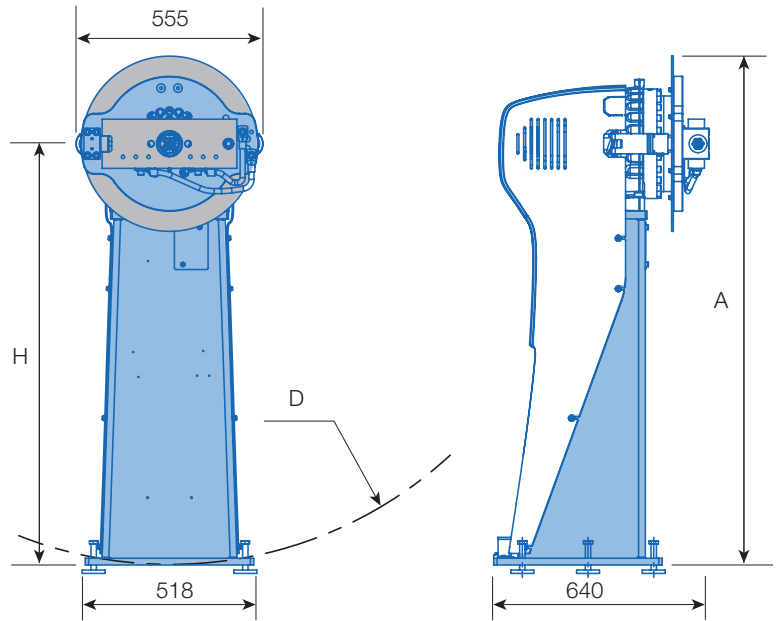

Type	Part No.	D	A	H
T-2000	149512-100	2000 mm	1167 mm	1000 mm
	149512-101	2500 mm	1417 mm	1250 mm
	149512-102	3000 mm	1667 mm	1500 mm
T-2000C	149515-100	2000 mm	1200 mm	1000 mm
	149515-101	2500 mm	1450 mm	1250 mm
	149515-102	3000 mm	1700 mm	1500 mm

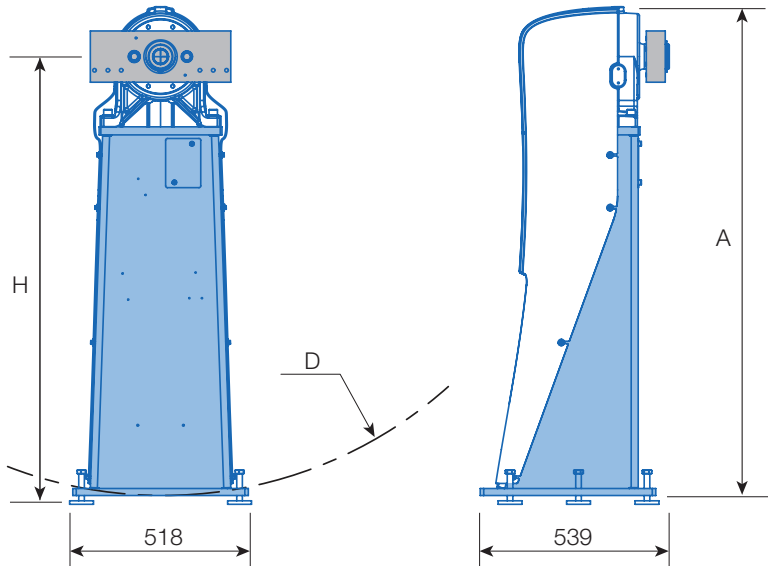

Options	Part No.
2x 3/8" air	141450-300
2x 3/8" air + Signal kit 4 channel I/O Fieldbus+PE	141475-302
2x 3/8" air + Signal kit 4 channel I/O ProfiNet+PE	141475-303
2x 3/8" air + Signal kit 12 channel I/O+PE	141475-300
2x 3/8" air + Signal kit 24 channel I/O+PE	141475-301